



浙江芯芯电子有限公司
ZHEJIANG XINXIN ELECTIRICAL CO., LTD.

产品规格书

Specification of Products

产品名称：平板型

产品型号：200A

浙江芯芯电子有限公司

ZHEJIANG XINXIN ELECTIRICAL CO., LTD.

地址：浙江省缙云县壶镇镇浙江丽缙五金科技产业园苍山区块内

电话：13857067071

邮编：321404

E-mail:247145749@qq.com

<http://www.zjxxdz1.com>

拟制	审核	核准
丁国盛	李园利	麻伟阳

版本号：04 更新日期：2022.6.28

SYMBOL	CHARACTERISTIC	TEST CONDITIONS	T _J (C)	VALUE			UNIT
				Min	Type	Max	
I _{F(AV)}	Mean forward current	180 half sinewave 50Hz Double side cooled, T _S =55C	150			560	A
I _{F(AV)}	Mean forward current	180 half sinewave 50Hz Double side cooled, T _S =90C	150			420	A
V _{RRM}	Repetitive peak reverse voltage	V _{RRM} tp=10ms V _{RSM} = V _{RRM} +100V	150	1100		2000	V
I _{RRM}	Repetitive peak current	at V _{RRM}	150			16	mA
I _{FSM}	Surge forward current	10ms half sine wave	150			7.3	KA
I ² T I	² T for fusing coordination	V _R =0.6V _{RRM}				265 A ² s*10 ³	
V _{FO}	Threshold voltage		150			0.70	V
r _F	Forward slop resistance					0.86	mΩ
V _{FM}	Peak onstate voltage I	I _M =1500A, F=5KN	150			1.99	V
I _m	Reverse recovery current		150			74.8	A
t _{rr}	Reverse recovery time	I _{TM} =600A, tp=1000s, di/dt=-40A/s, V _R =50V				4.0	s
Q _{rr}	Recovery charge					159.7	C
R _{th(j-h)}	Thermal resistance Junction to heatsink	At 180° sine double side cooled Clamping force 5.0KN				0.090	C /W
F _m	Mounting force			3.3		5.5	KN
T _{stg}	Stored temperature			-40		160	C
W _t	Weight				50		g
Outline	ZT19aT						

Outline

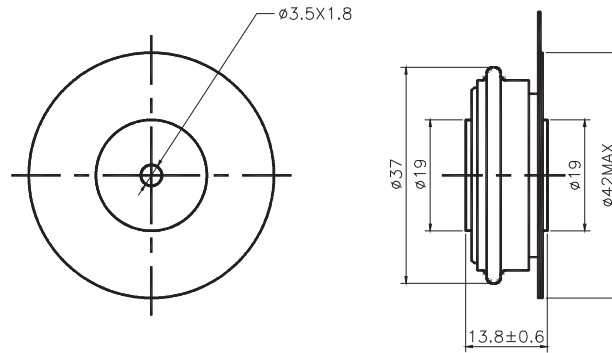

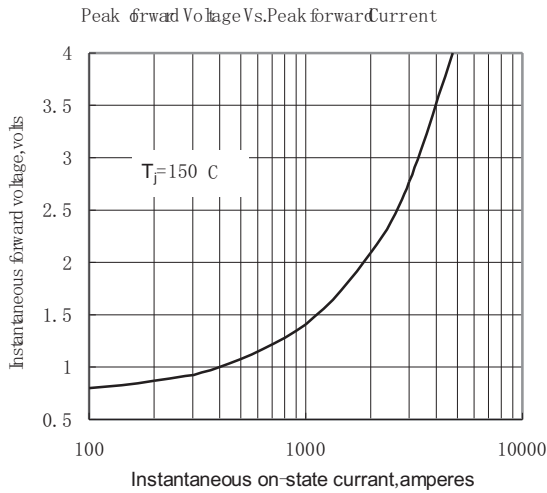

Fig. 1

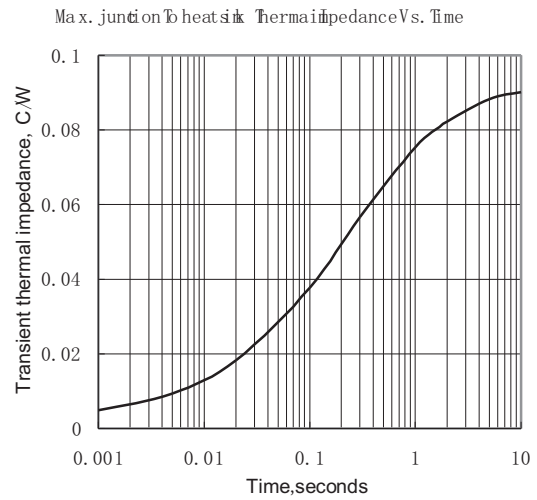

Fig. 2

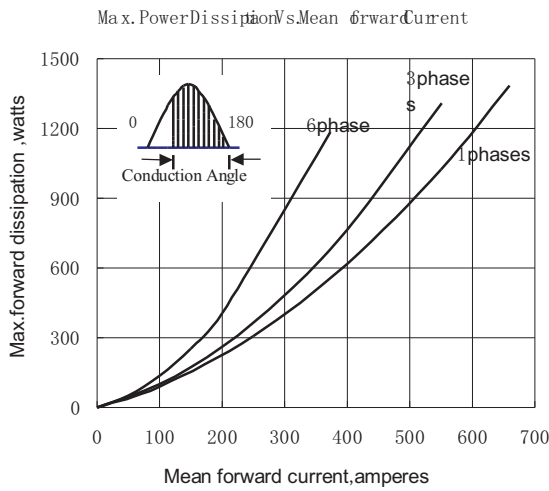

Fig. 3

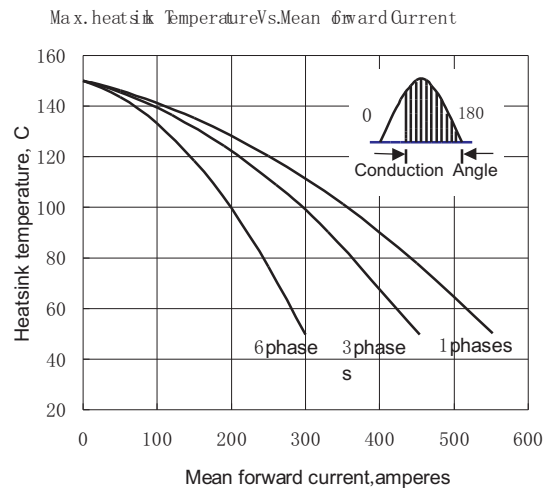

Fig. 4

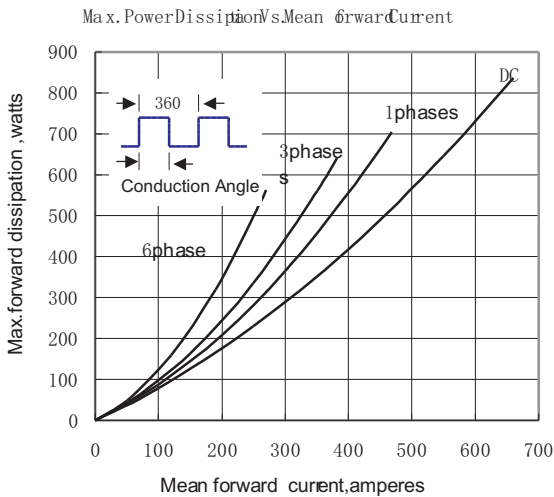

Fig. 5

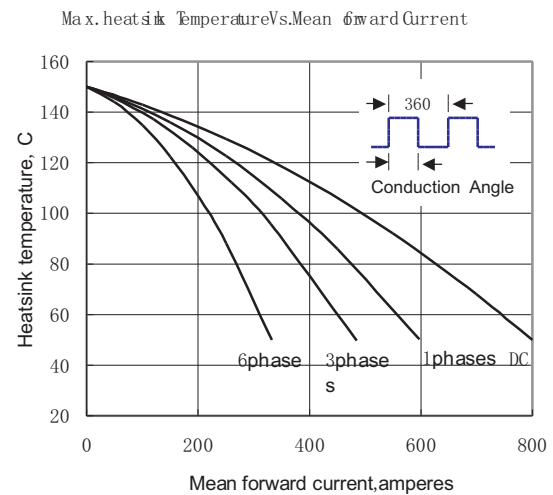

Fig. 6