

产品规格书

Specification of Products

产品名称：可控硅模块

产品型号：MTC300A

浙江芯芯电子有限公司

ZHEJIANG XINXIN ELECTIRICAL CO., LTD.

地址：浙江省缙云县壶镇镇浙江丽缙五金科技产业园苍山区块内

电话：13857067071

邮编：321404

E-mail:247145749@qq.com

<http://www.zjxxdz1.com>

拟制	审核	核准
丁国盛	李园利	麻伟阳

SYMBOL	CHARACTERISTIC	TEST CONDITIONS	T _j (°C)	VALUE			UNIT
				Min	Type	Max	
I _{T(AV)}	Mean on-state current	180° half sinewave 50Hz Single side cooled, T _j =85°C	125			300	A
I _{T(RMS)}	RMS on-state current	Single side cooled, T _j =85°C	125			471	A
V _{DRM} V _{RRM}	Repetitive peak on-state voltage Repetitive peak reverse voltage	V _{DRM} &V _{RRM} tp=10ms V _{DSM} &V _{RSM} = V _{DRM} &V _{RRM} +200V respectively	125	600		1600	V
I _{DRM} I _{RRM}	Repetitive peak current	at V _{DRM} at V _{RRM}	125			30	mA
I _{TSM}	Surge on-state current	10ms half sinewave	125			7.20	KA
I ² t	I ² T for fusing coordination	V _R =60%V _{RRM}				264	A ² s*10 ³
V _{TO}	Threshold voltage		125			0.80	V
r _T	On-state slop resistance					1.27	mΩ
V _{TM}	Peak on-state voltage	I _{TM} =900A	125			1.5	V
dv/dt	Critical rate of rise of off-state voltage	V _{DM} =67%V _{DRM}	125			800	V/μs
di/dt	Critical rate of rise of on-state current	From 67%V _{DRM} To 600A, Gate source 1.5A t _r ≤ 0.5 μs Repetitive	125			150	A/μs
I _{GT}	Gate trigger current			30		180	mA
V _{GT}	Gate trigger voltage	V _A =12V, I _A =1A	25	1.0		2.5	V
I _H	Holding current			20		100	mA
V _{GD}	Non-trigger gate voltage	At 67%V _{DRM}	125			0.2	V
R _{th(j-c)}	Thermal resistance Junction to heatsink	At 180° sine Single side cooled				0.140	°C /W
V _{iso}	Isolation voltage	50Hz, RM. S, t=1min, i _{so} : 1mA MAX)		2500			V
F _m	Thermal connection torque(M8)					4.5	N.m
	Mounting torque(M6)					3.0	N.m
T _{stg}	Stored temperature			-40		140	°C
W _i	Weight					900	g
Outline							

OUTLINE DRAWING & CIRCUIT DIAGRAM

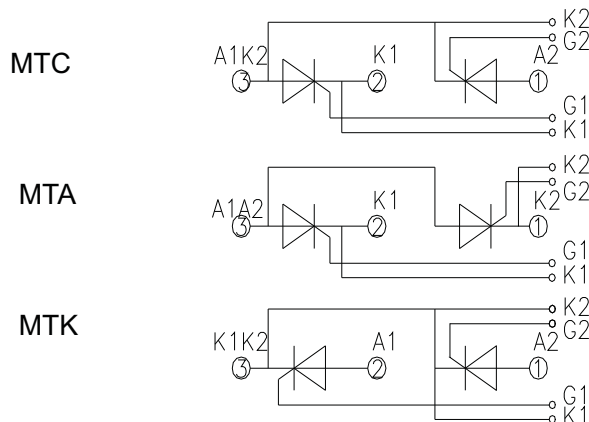

Rating and Characteristic

Peak On-state Voltage Vs. Peak On-state Current

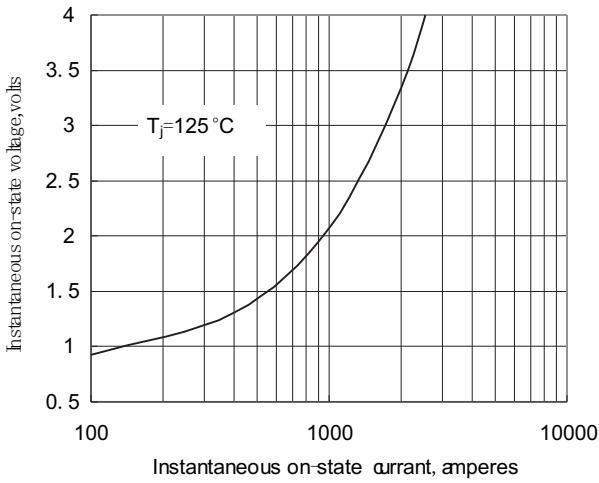

Fig. 1

Max. junction case The Impedance Vs. Time

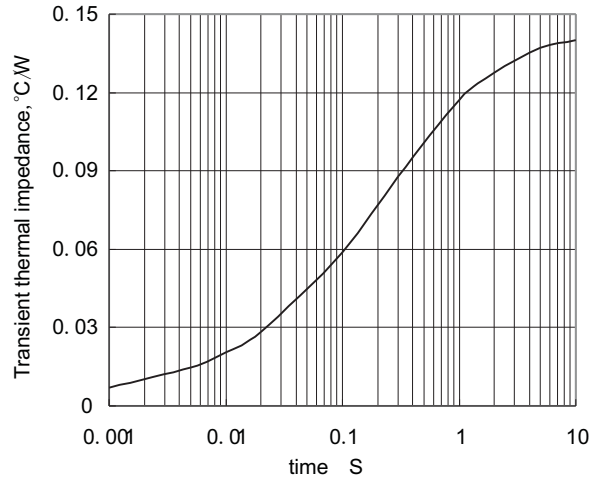

Fig. 2

Max. Power Dissipation Vs. Mean On-state Current

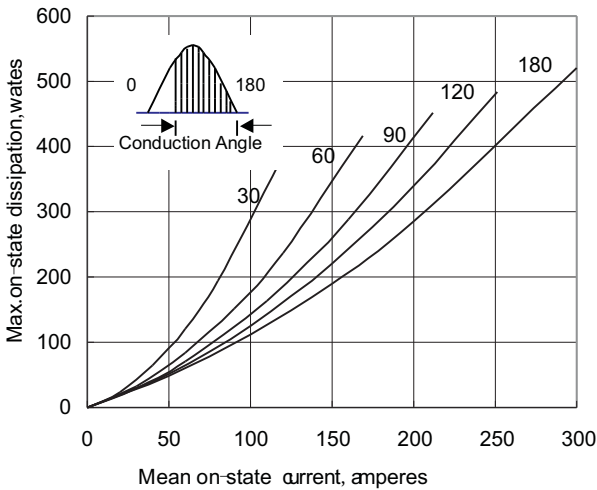

Fig. 3

Max. case Temperature Vs. Mean On-state Current

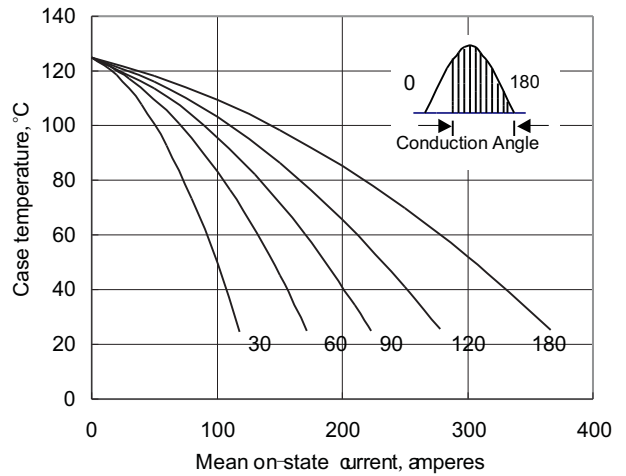

Fig. 4

Max. Power Dissipation Vs. Mean On-state Current

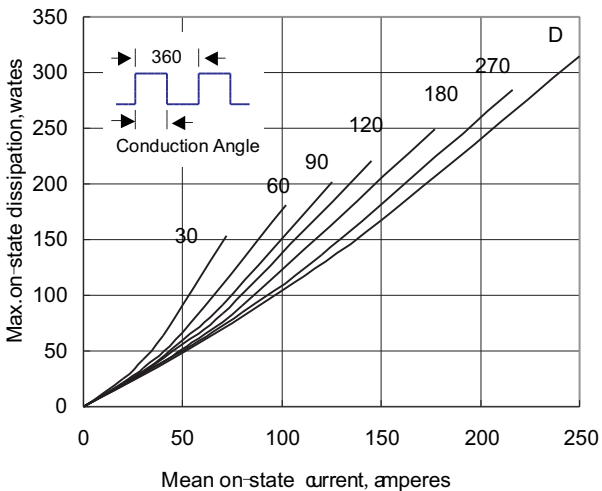

Fig. 5

Max. case Temperature Vs. Mean On-state Current

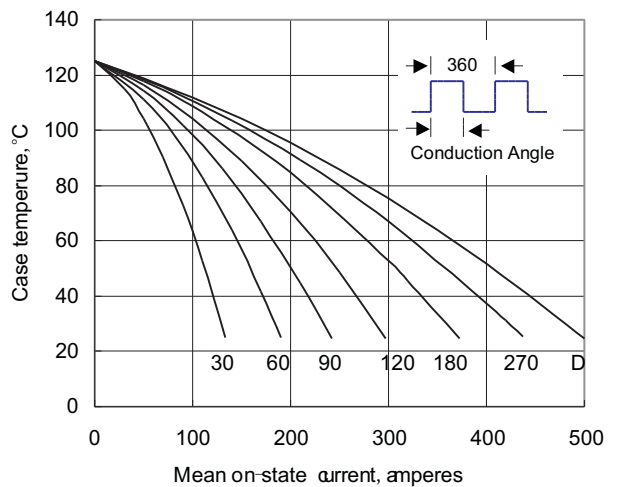

Fig. 6

Rating and Characteristic

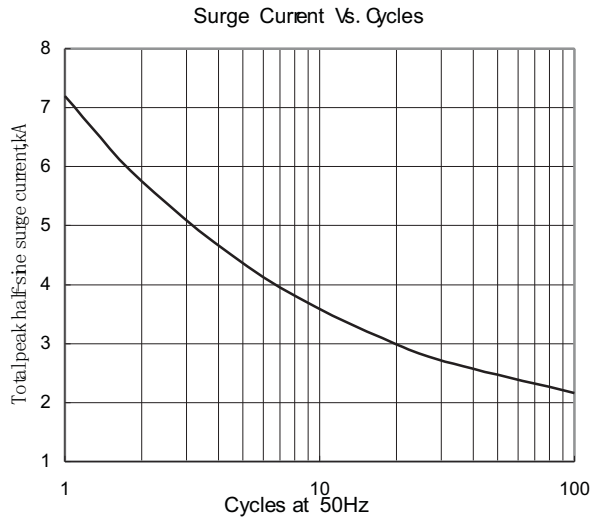

Fig. 7

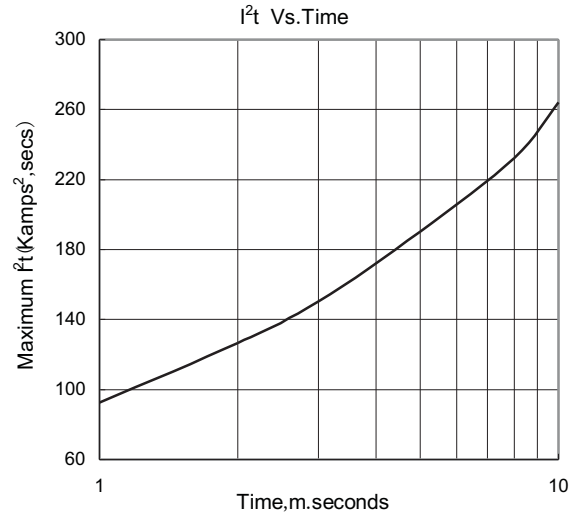

Fig. 8

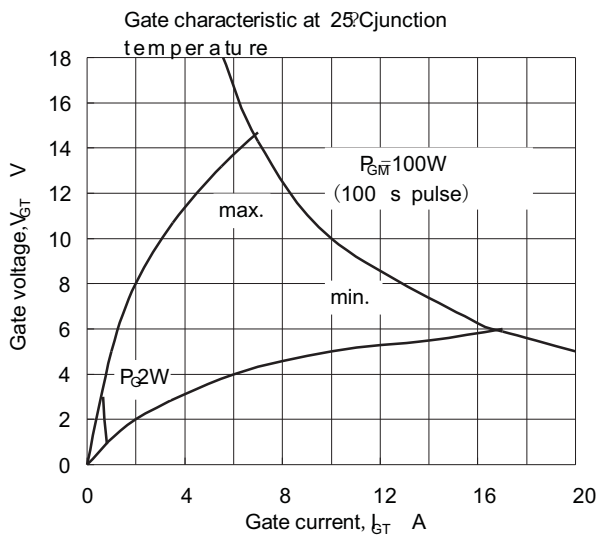

Fig. 9

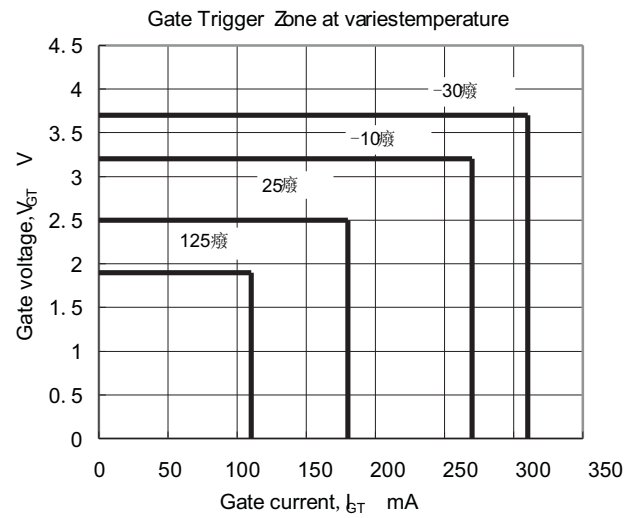

Fig. 10

Outside Dimension

